

# **Activating the Social Workscape**

**Danyel Fisher**

**UC Irvine**

**ISR**

**June, 2003**

# Outline

- Collaborating ...  
and telling your computer about it
- Social networks, temporal patterns
- Automatically recognizing patterns
- Design implication

# **(not so) Secretly, You Are Collaborating**

- **Group-edited documents**
- **Shared calendars**
- **Social navigation**
  - **Amazon recommendations?**

Create Mail
 Reply
 Reply All
 Forward
 Print
 Delete
 Send/Recv
 Addresses
 Find
 Purge
 IMAP Folders

Inbox

- Outlook Express
- Local Folders
  - Inbox
  - Outbox (1)
  - Sent Items
  - Deleted Items (1)
  - Drafts
- Irvine
  - Inbox (2)
  - Sent Items
  - Drafts
  - Amazon
  - AoIR
  - berkeley grad stuff
  - council
  - Ext
  - Friends
  - housing
  - inbox-pre-0208
  - inbox-pre-0303
  - jpd
  - jung
  - lists
  - Michelle
  - MOO
  - NetMeeting
  - old
  - old address (1)
  - OldSent
  - one virus
  - outdoors

From	Subject	Sent	Size	To
Michelle Moore	RE: Some fun political thought...	6/9/2003 10:10 AM	7KB	Danyel Fisher
Christopher Cobb	Call for review, time sensitive	6/9/2003 10:09 AM	6KB	Strange Horiz...
Megan Rijpe O'Madadhain	Re: quick quiz	6/9/2003 9:18 AM	5KB	Nora Williams;
nemptage@uci.edu	dinner list	6/9/2003 9:13 AM	2KB	danyelf@acm.
Orzechowski, Talana C	RE: Party next Sunday	6/9/2003 9:13 AM	3KB	'Danyel Fisher'
air-l-request@aoir.org	Air-l digest, Vol 1 #742 - 1 msg	6/9/2003 9:01 AM	4KB	air-l@aoir.org
Paul Dourish	Re: Party next Sunday	6/9/2003 8:52 AM	2KB	Danyel Fisher
L-Soft list server at ACM...	Message (*Your message dated Mon, 9 Jun 2003 07:...	6/9/2003 7:49 AM	2KB	danyelf@ACM
Danyel Fisher	ECSCW 2003 Workshop on Social Networks 2nd CALL	6/9/2003 7:49 AM	6KB	CHI-ANNOUNC
Peter J Wild	Cfp: HCI 2003 Workshop on "Temporal Aspects of Ta...	6/9/2003 7:17 AM	11KB	CHI-ANNOUNC
Amtrak	Danyel, Save 25% Online at Amtrak.com. Hurry Ends...	6/9/2003 7:10 AM	6KB	Danyel Fisher
Evite	Taco Tuesday - 6/10/03	6/9/2003 12:18 AM	7KB	danyelf@acm.
Sameer Patil	NYC	6/8/2003 11:11 PM	2KB	Danyel Fisher

**From:** Peter J Wild **To:** CHI-ANNOUNCEMENTS@ACM.ORG  
**Subject:** Cfp: HCI 2003 Workshop on "Temporal Aspects of Tasks"

Call for participation, Workshop on the Temporal Aspects of Tasks.  
  
 Workshop at HCI2003, University of Bath, U.K.  
  
 Monday 8th September 2003  
  
 All day workshop  
  
 Contributions in the form of 6 page position papers are invited for a workshop at HCI2003 on the Temporal Aspects of Tasks.

# My view of today

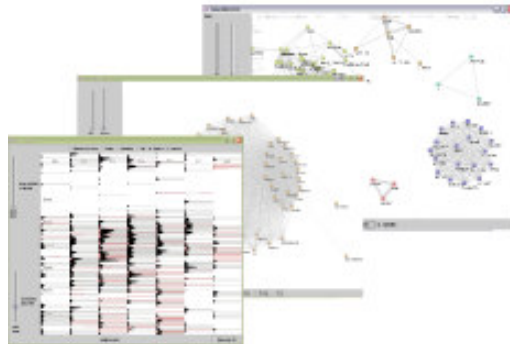

**Activating the Social Workspace**  
Danyel Fisher Paul Dourish

...are collaborating...  
...and your computer doesn't know it.

Your applications allow you to interact with many others in repeatable, meaningful ways.

We want to design applications that understand the social workspace.

If we can make the regularities in the workspace visible, we can build applications that use them.

These patterns can be mined automatically and used for future tools.

**Visualizing Email**  
Visualizing email messages and their relationships.

**Visible Networks**  
Visualizing social networks and their relationships.

**Temporal Display**  
Visualizing social networks over time.

**Changing Roles**  
Visualizing social networks and their relationships over time.

**The Manager**  
Visualizing social networks and their relationships.

**The Decision**  
Visualizing social networks and their relationships.

**The Future**  
Visualizing social networks and their relationships.

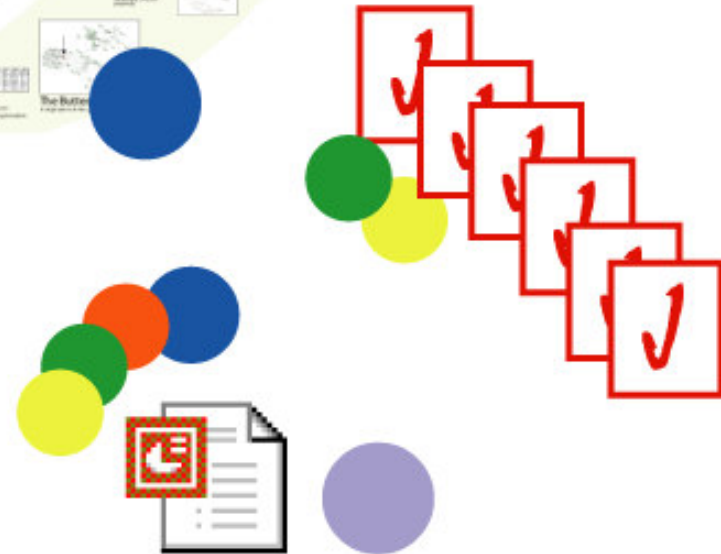



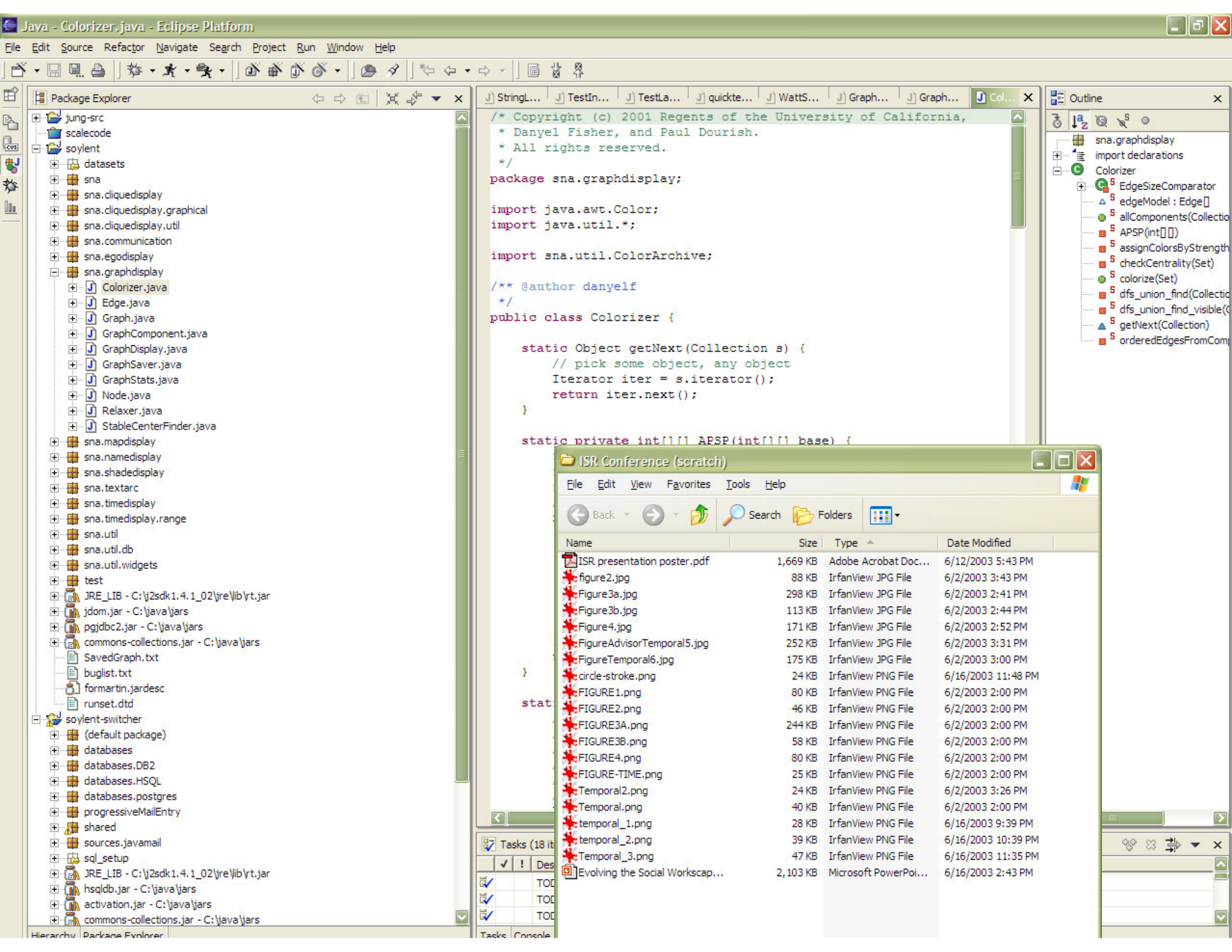

# **Making Relationships Visible**

- To you
- To your computer

# Structured Interaction

- Repeatable patterns
- People have roles (often multiple)
- Detectable social arrangements



# Types of Patterns

- Social network
- Temporal: schedules and changes

# Detecting Patterns

- Email outbox
- Database
- Visualization of results
- Interviews, and analysis of visualizations

From: A@here.now

To: X@uci.edu, Y@berkeley.edu

Date: Monday, 4:00 pm

Traditional

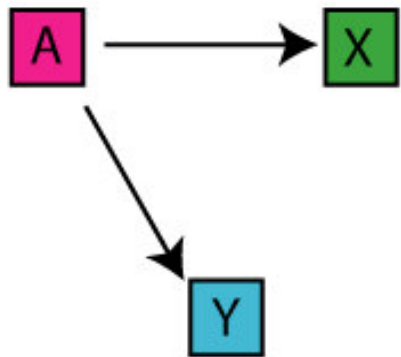

Ego-Centric

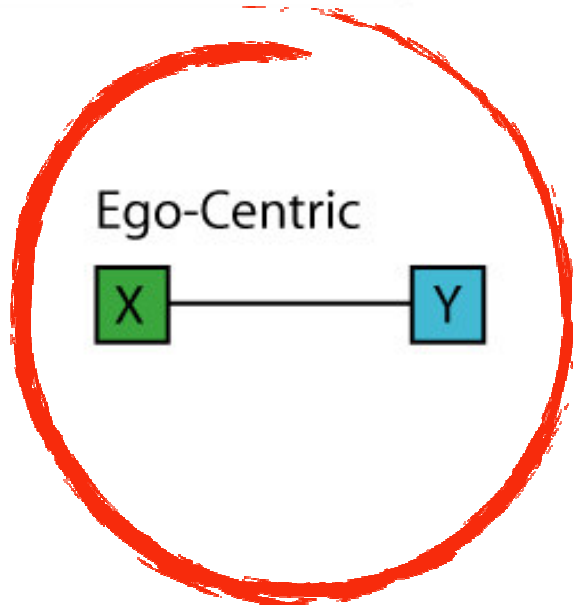

Temporal

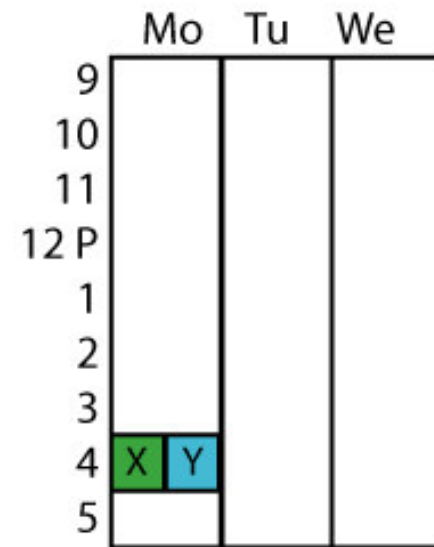

From: A@here.now  
To: X@uci.edu, Y@berkeley.edu  
Date: Monday, 4:00 pm

From: A@here.now  
To: Y@berkeley.edu, Z@uci.edu  
Date: Wednesday, 12:00 pm

Traditional

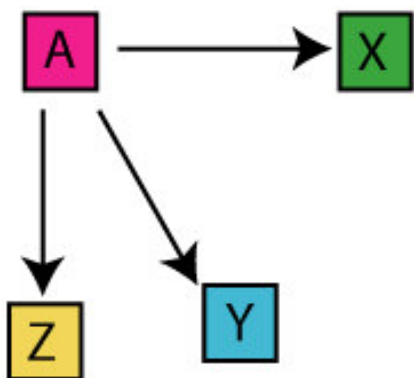

Ego-Centric

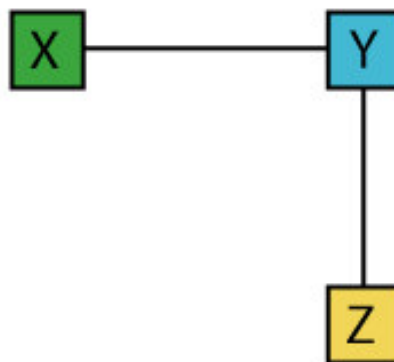

Temporal

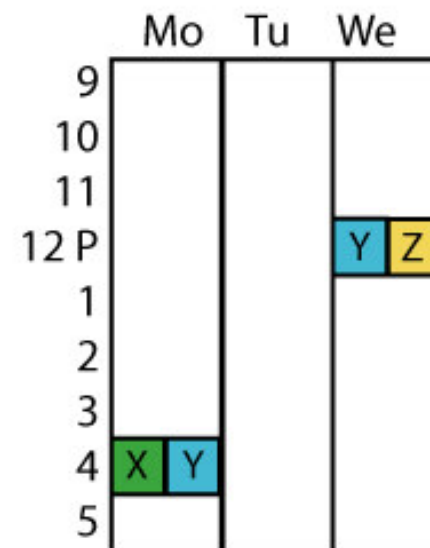

From: A@here.now

To: X@uci.edu, Y@berkeley.edu

From: A@here.now

To: W@boeing.com, V@ibm.com, Z@uci.edu

Date: Monday, 11:00 am

From: A@here.now

To: Y@berkeley.edu, Z@uci.edu

pm

Traditional

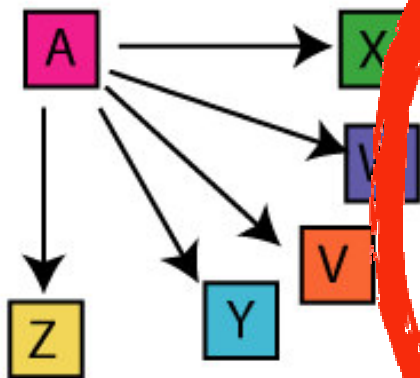

Ego-Centric

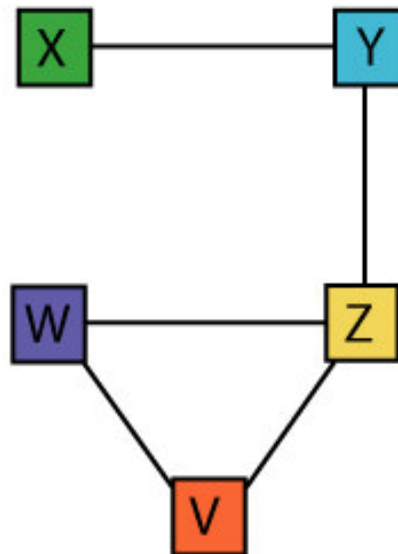

Temporal

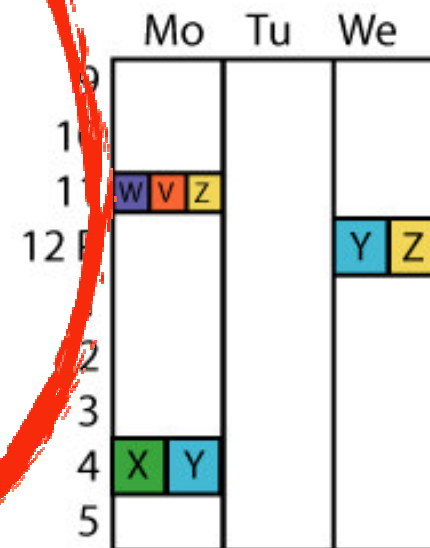

**ties**

min tie strength stretch

**time**

start time end time

Show all

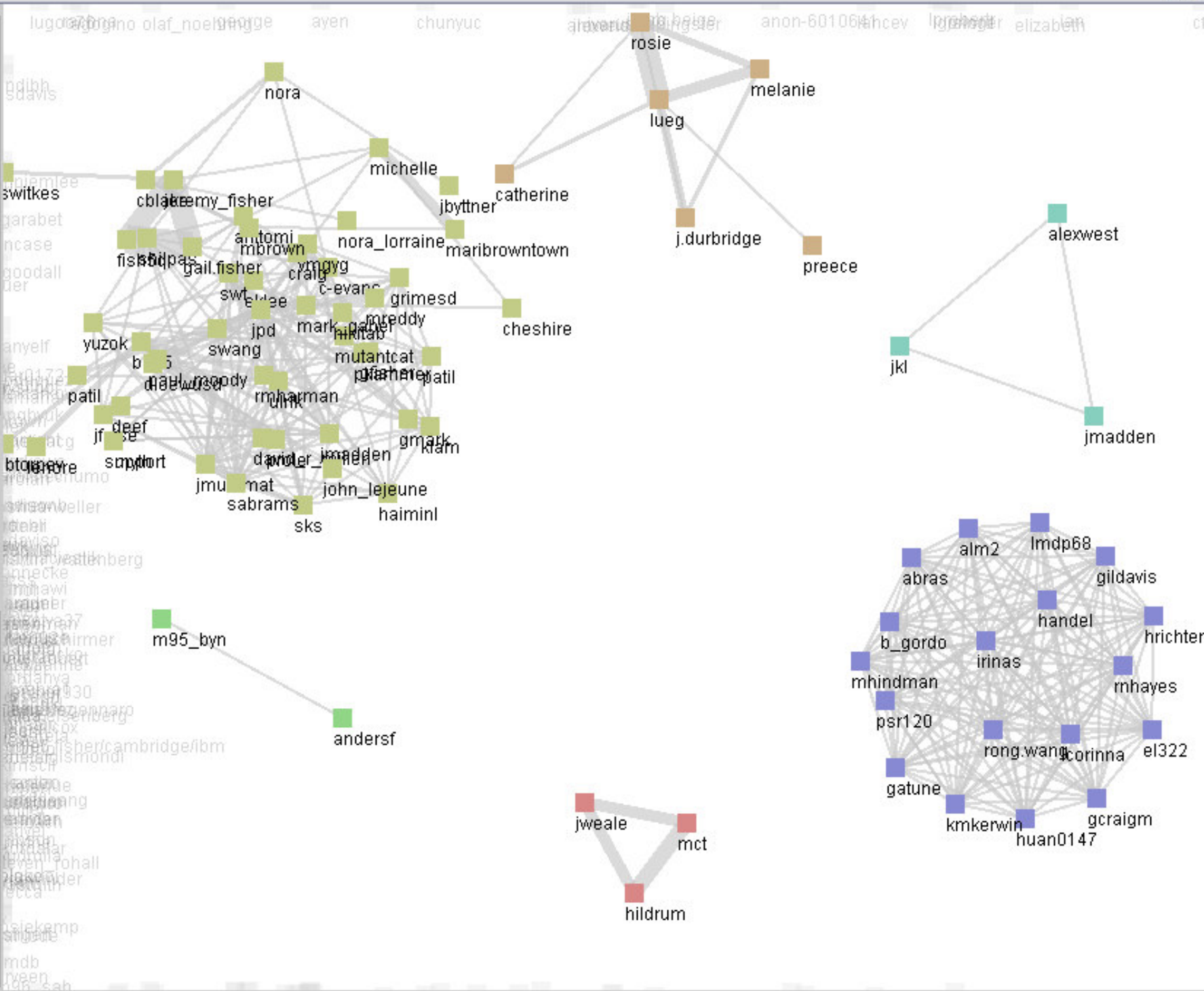

# Field Site

- IBM/Cambridge
- In association with research group
- Extended interviews
  - Researchers
  - Developers
  - Managers and Secretaries
- Ran the program on their mail...  
and looked over their shoulders



# Results

- Patterns are based on real data from participants
- The images are a mix of UCI and IBM results, anonymized
- Recurrent, meaningful patterns tied to stories and events

**(network patterns)**

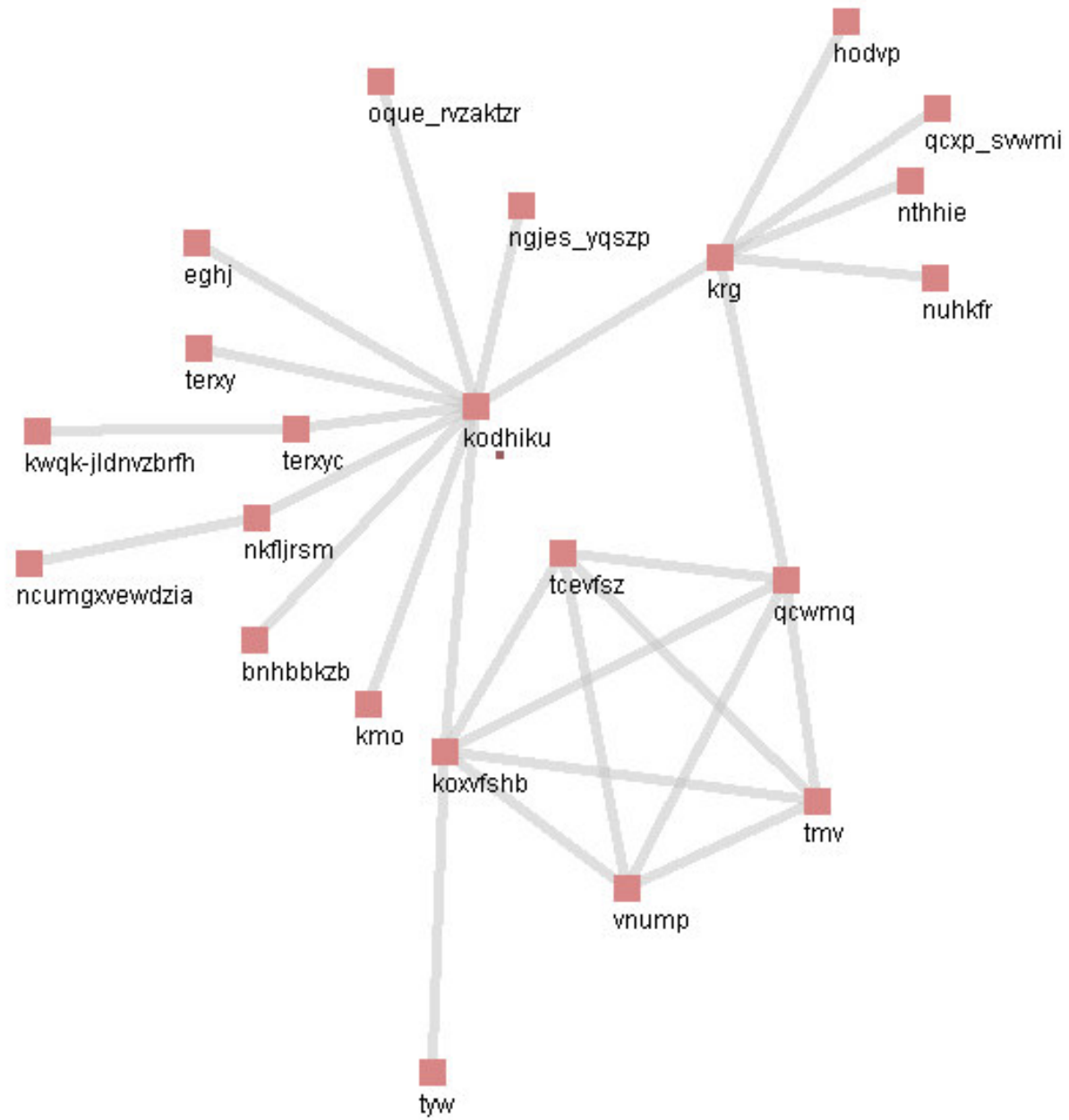

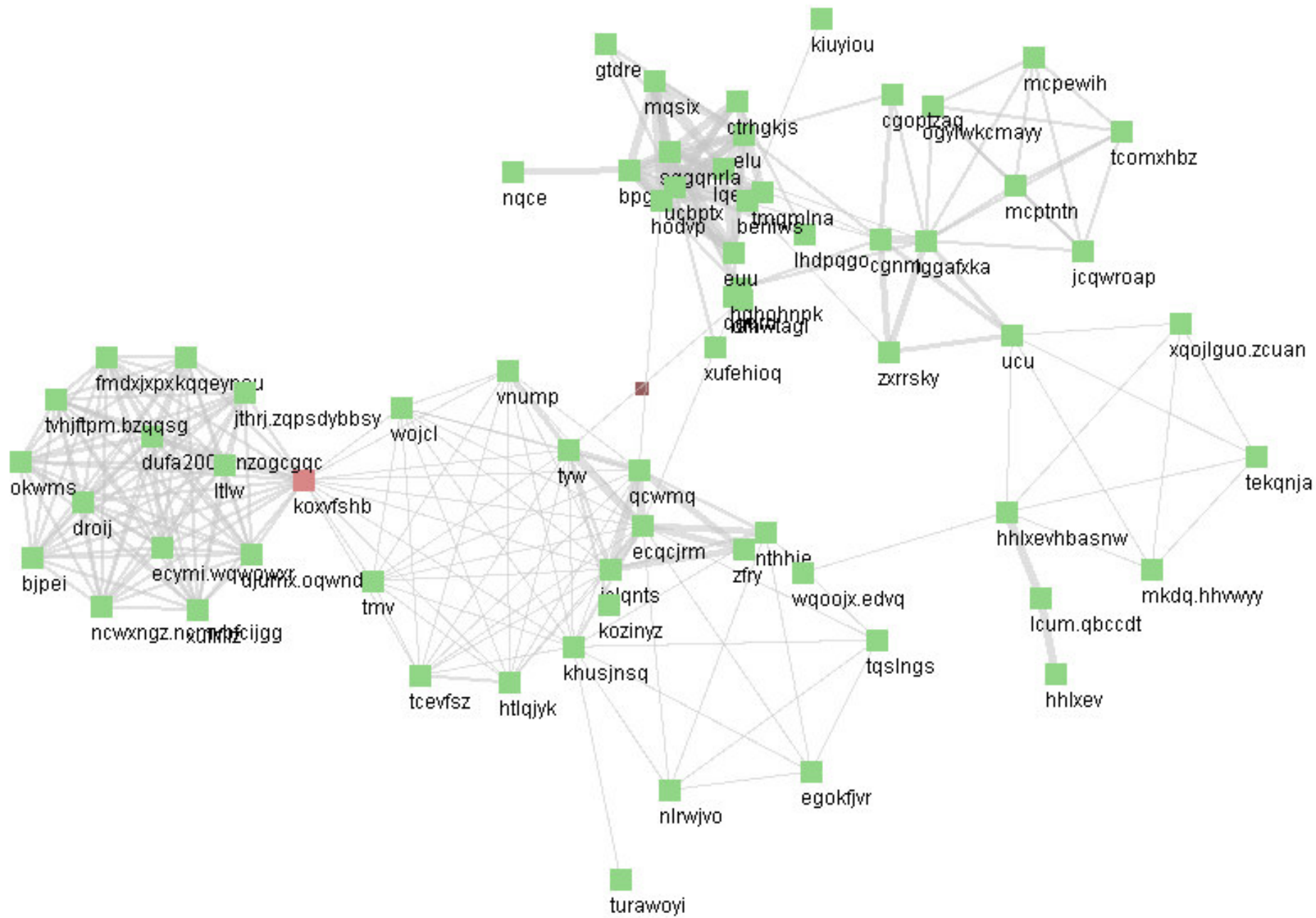

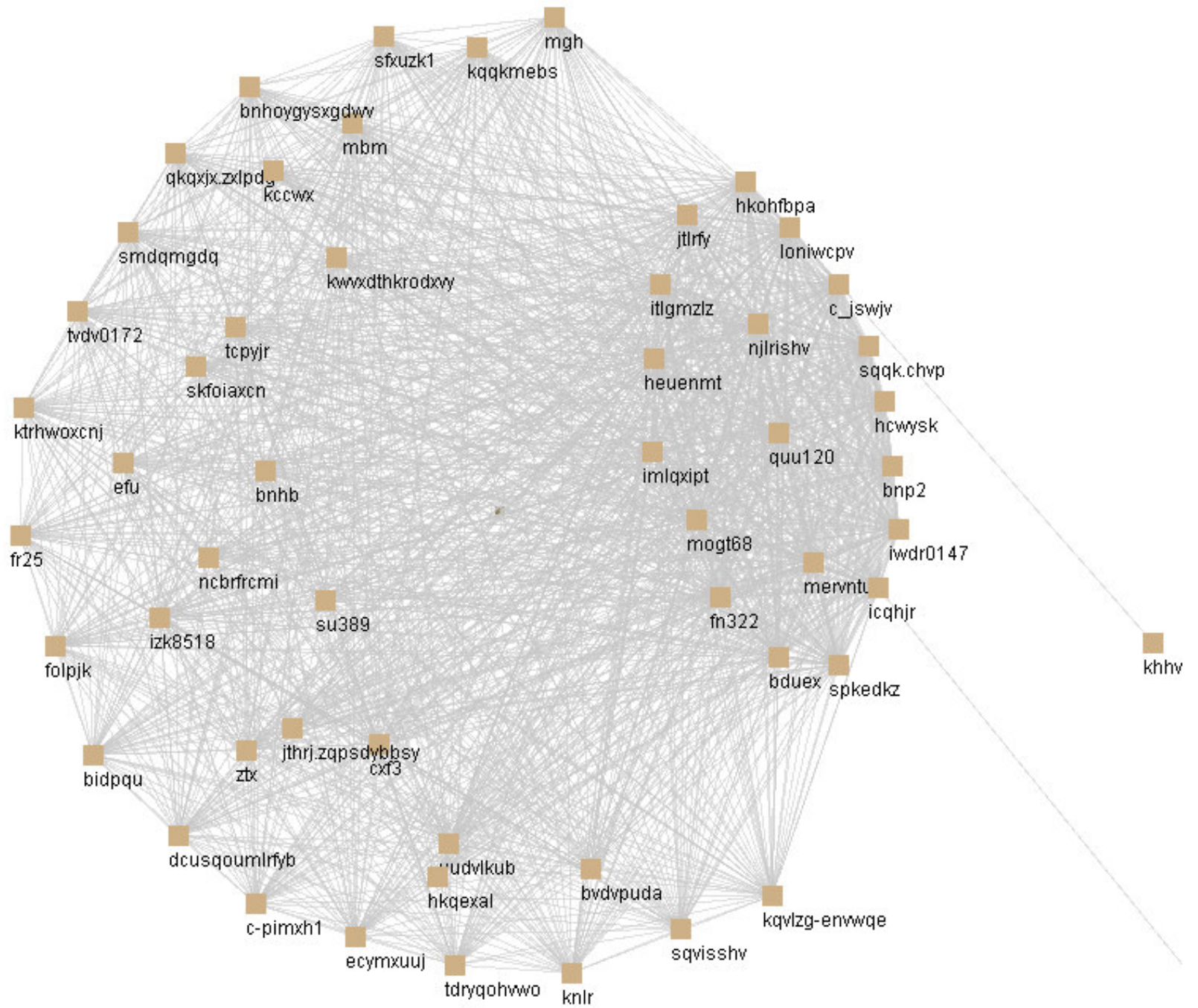

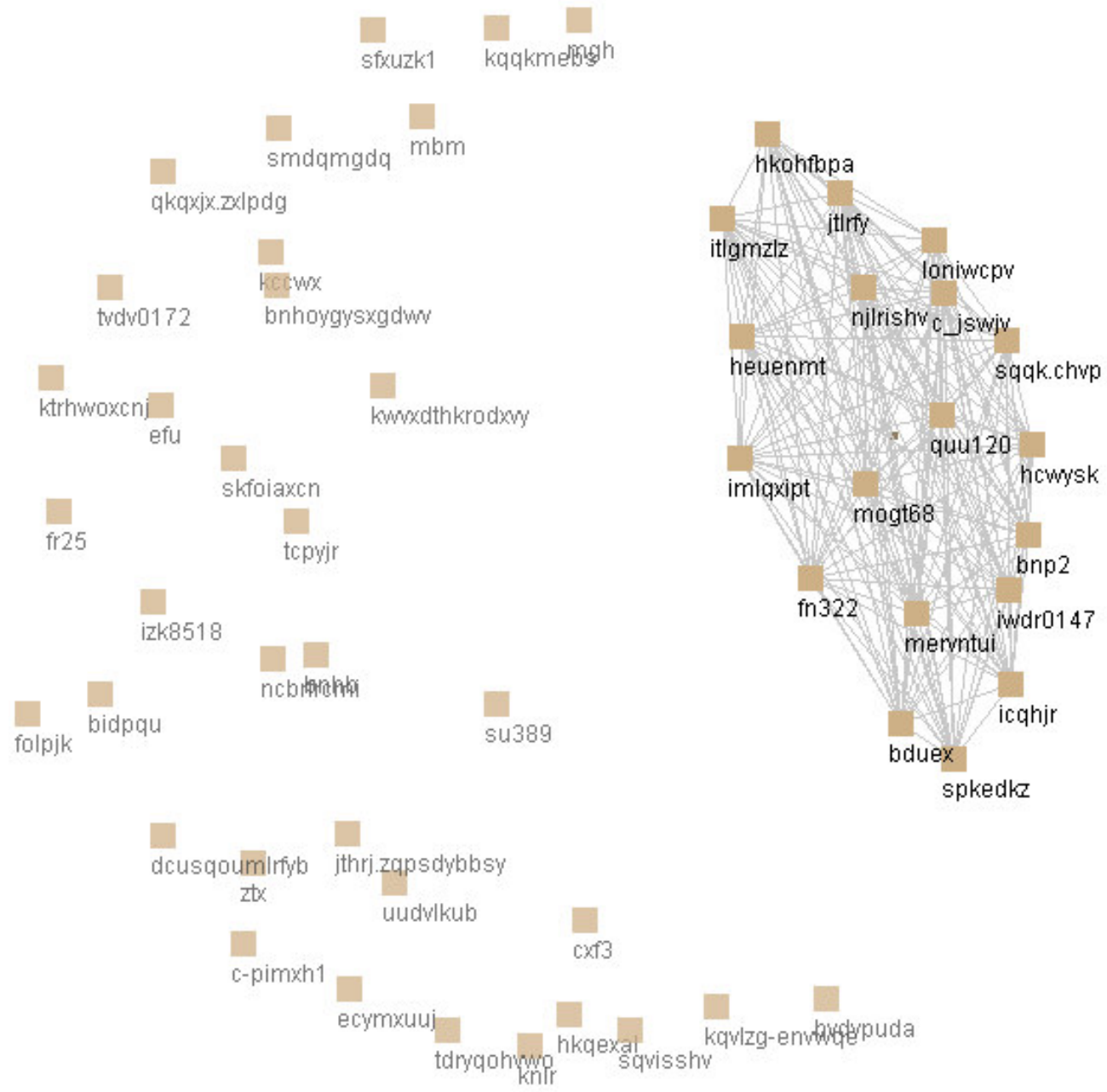

**(temporal patterns)**



Monthly Top 10 List

Apr 02	May 02	Jun 02	Jul 02	Aug 02	Sep 02	Oct 02	Nov 02	Dec 02	Jan 03	Feb 03	Mar 03	Apr 03	May 03
hghohnpk	hghohnpk	hghohnpk	hghohnpk	hghohnpk	hghohnpk	hghohnpk	hghohnpk	hghohnpk	hghohnpk	hghohnpk	hhlxevhba	ecqcjrm	hghohnpk
ecqcjrm	qcwmq	qcwmq	ecqcjrm	ecqcjrm	ecqcjrm	mqsix	nthhie	sggqnrla	hodvp	sggqnrla	hghohnpk	hghohnpk	ecqcjrm
cgnm	ecqcjrm	ecqcjrm	tyw	cgnm	qcois	sggqnrla	mqsix	hodvp	bpgvj	hghohnpk	qslngs	qslngs	qslngs
hodvp	hodvp	cgnm	qcwmq	qcwmq	sggqnrla	hodvp	hodvp	mqsix	sggqnrla	ecqcjrm	ecqcjrm	hodvp	cgnm
sggqnrla	elu	nthhie	iclnqts	tyw	cgoptzaq	ecqcjrm	meimsrlg	bpgvj	lqewf	hodvp	hodvp	sggqnrla	sggqnrla
nthhie	tyw	tyw	sggqnrla	hodvp	mqsix	bpgvj	ecqcjrm	qqqrd	ecqcjrm	hhlxevhba	tcevfsz	elu	nthhie
wojcl	kdbxytlz	lggafxka	ctrhgkjs	qcois	hodvp	qqqrd	sggqnrla	elu	ecqcjrm	tcevfsz	nlrwjvo	egokfjvr	elu
fncwqpp	nthhie	iclnqts	cgnm	ctrhgkjs	cgnm	khusjnsq	ecqcjrm	ecqcjrm	ucbptx	qslngs	sggqnrla	ucbptx	dfhwtagi
beniws	sggqnrla	sggqnrla	hodvp	bpgvj	bpgvj	lqewf	ecq	ltlw	mqsix	mqsix	khusjnsq	nlrwjvo	hhlxevhba
elu	iclnqts	elu	bpgvj	sggqnrla	hhlxev	elu	ucbptx	qcwmq	elu	ucbptx	eqewyllt	nthhie	qqqrd

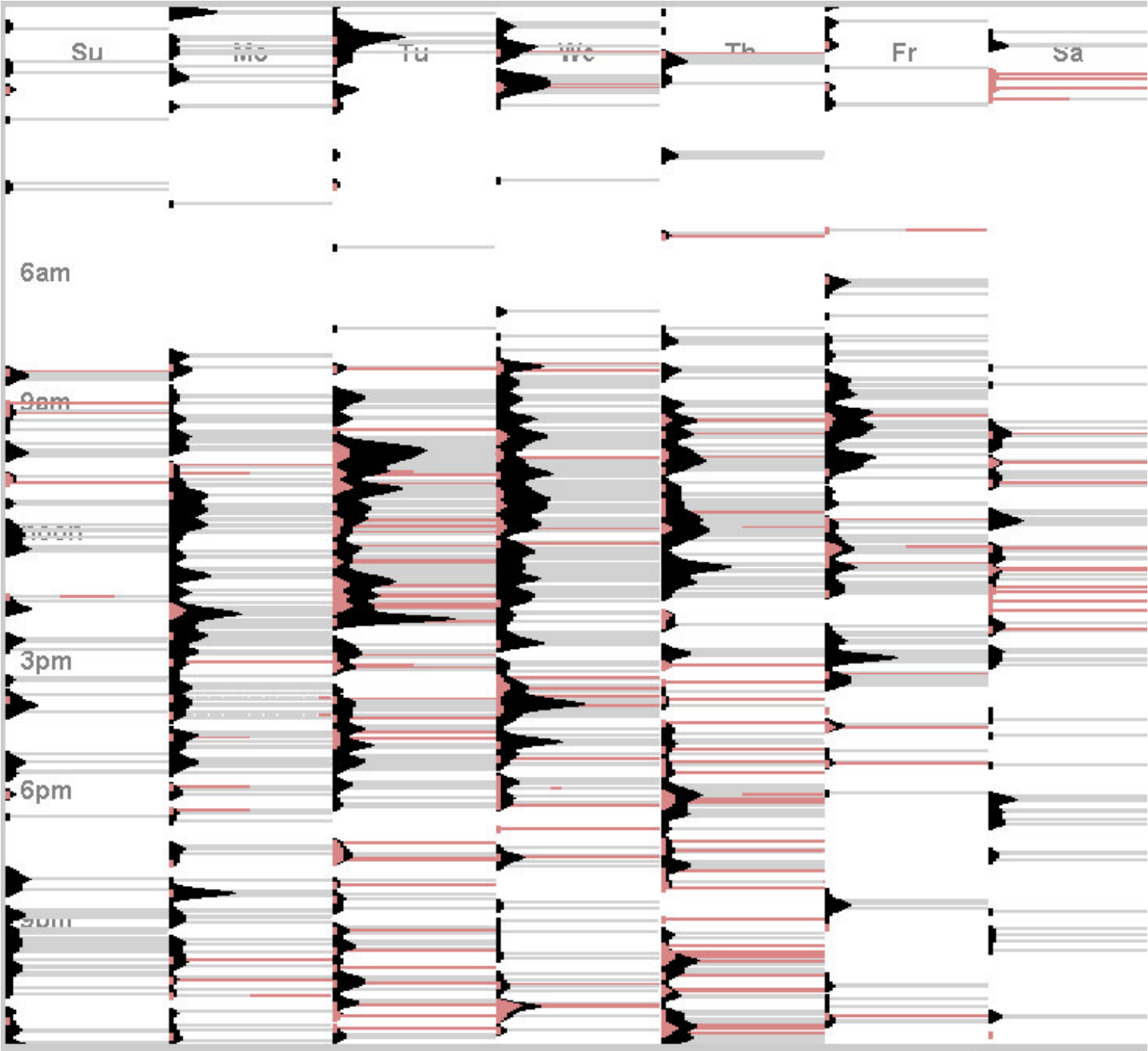

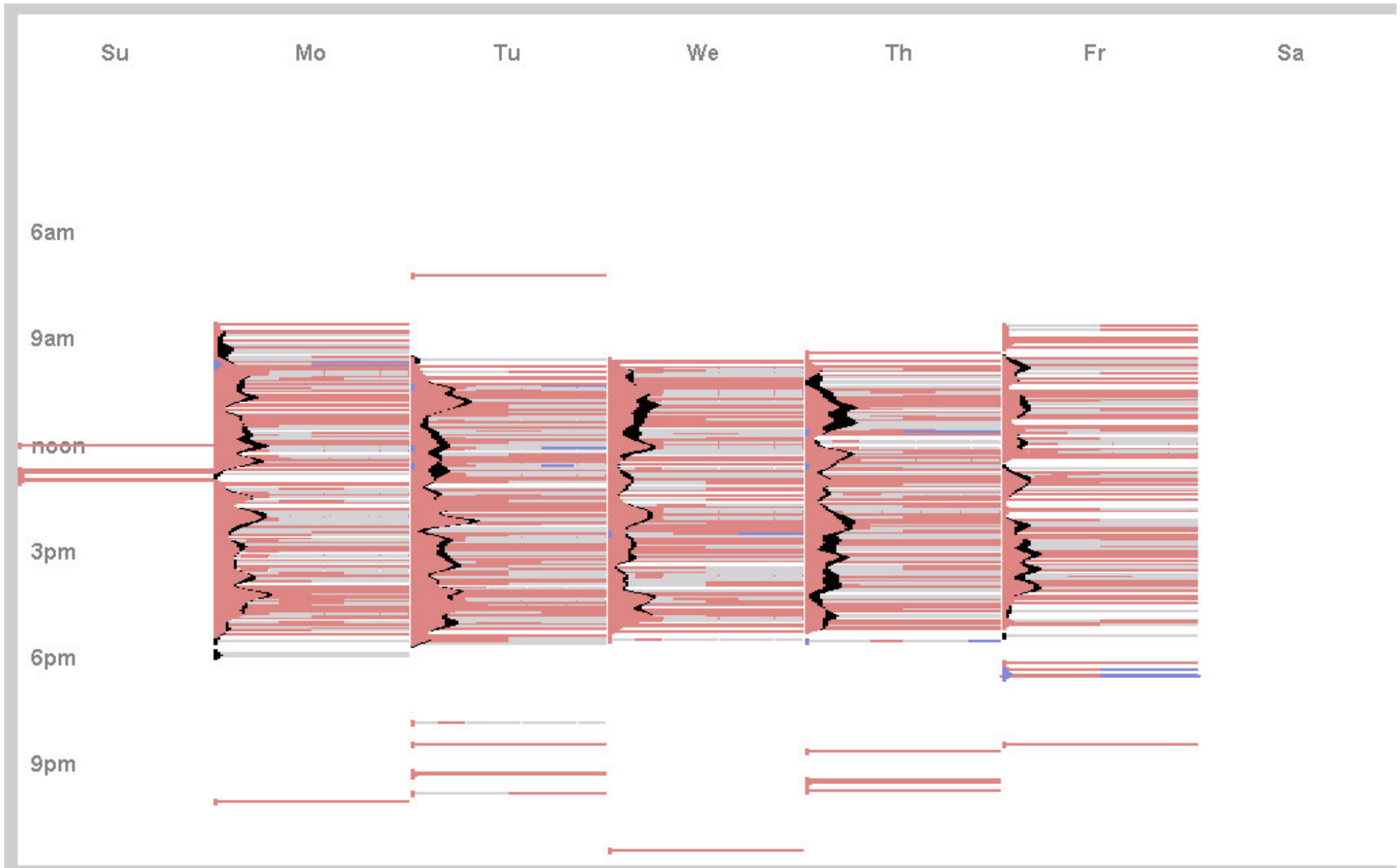

6am

9pm

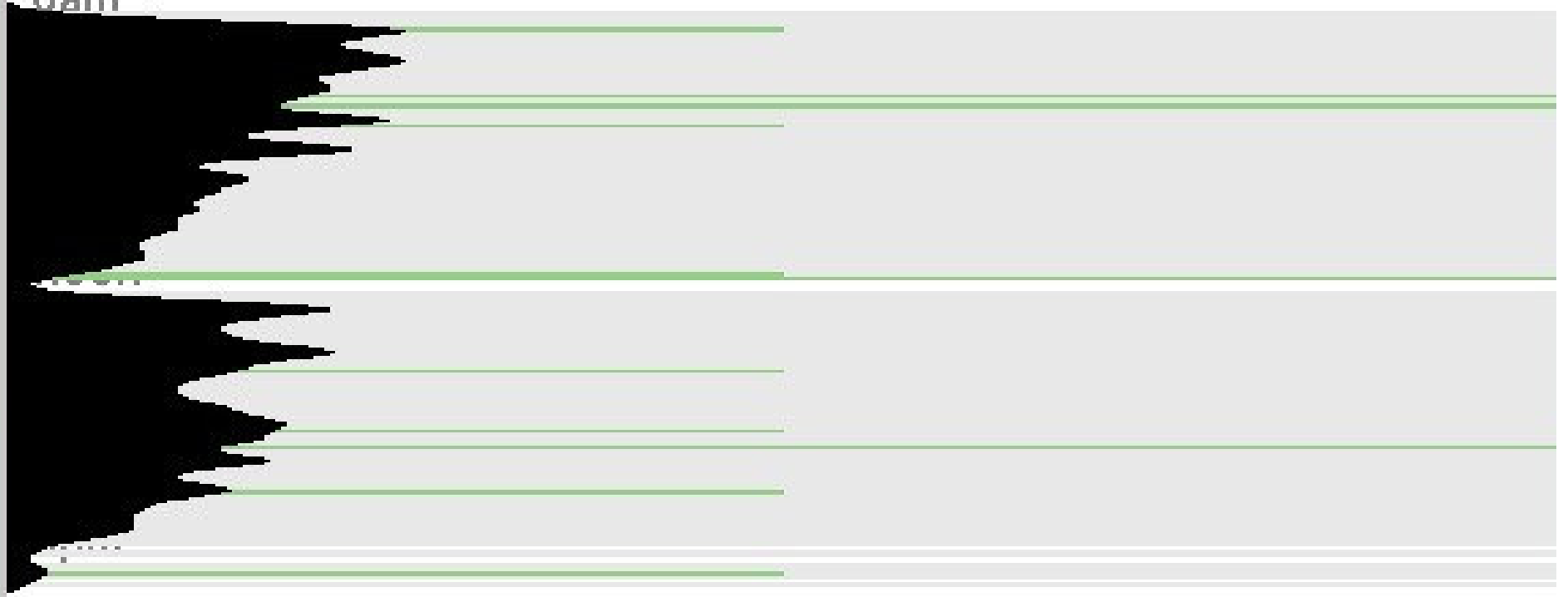

# Results

- regularity
- detectable, meaningful patterns
  - Manager
  - Butterfly
  - Onion
  - Schedules
  - Changes in time

# **Future Plans**

- **Tools that know about patterns**
- **Tools that know about people**

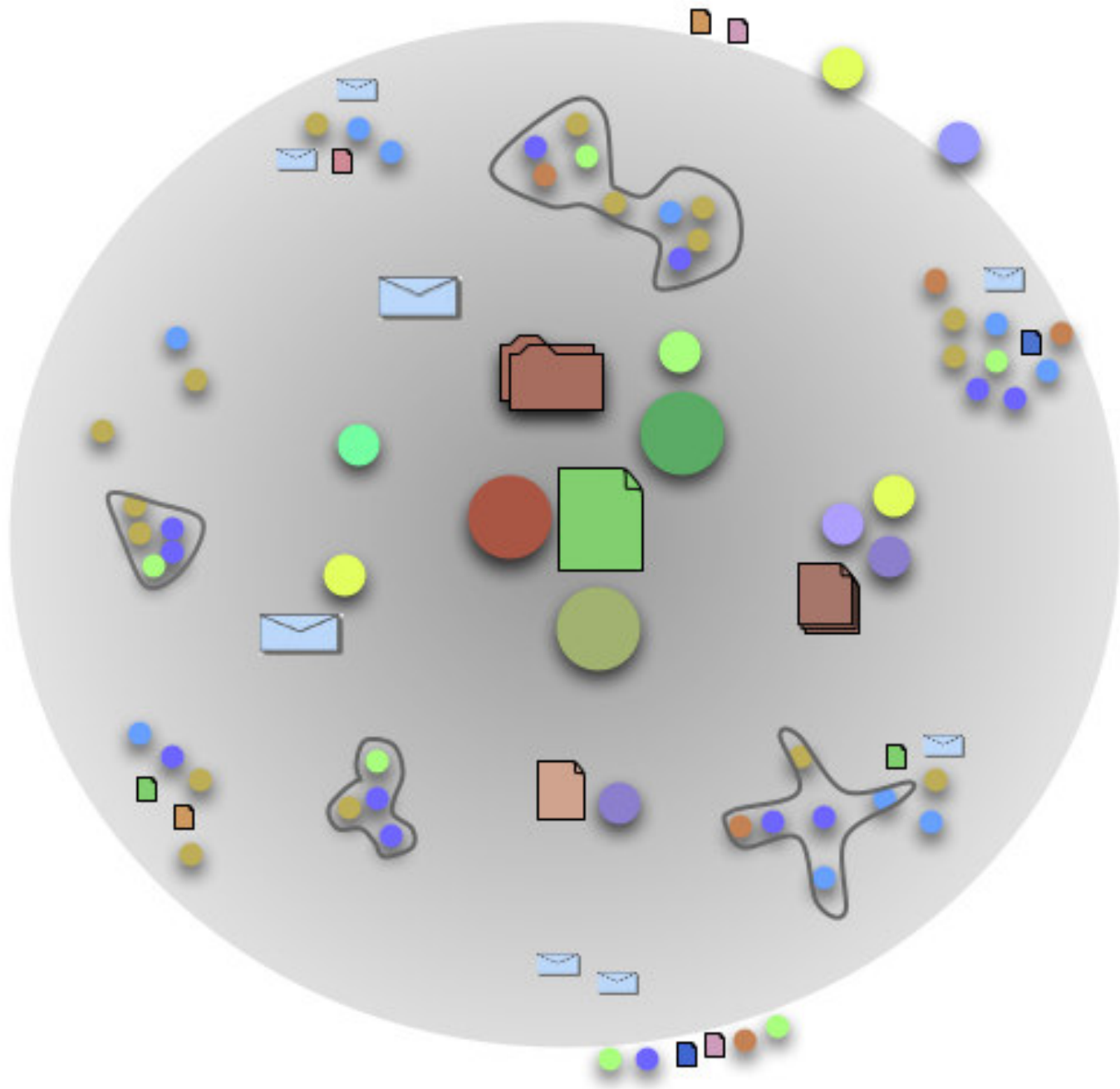



# Other media

- Demo
- Poster

# Thanks!

- [danyelf@acm.org](mailto:danyelf@acm.org)
- <http://www.ics.uci.edu/~danyelf>